

# ALUMINIUM GANTRY CRANE

sample documentation

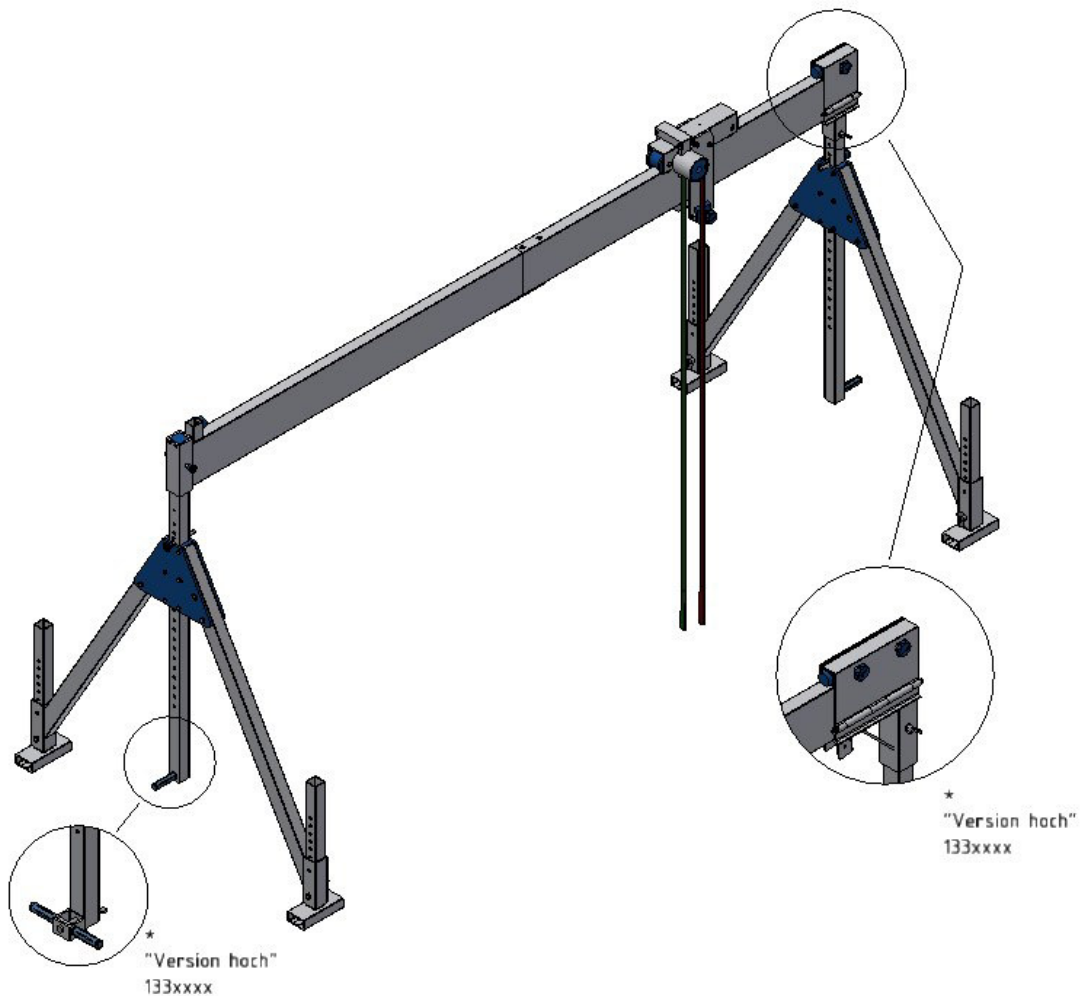

## USER INFORMATION

The assembly, operating and maintenance instructions for SCHILLING products must be observed at all times.

Users and/or their personnel must read the instructions thoroughly and understand them fully before using the product.

Please retain this user information for future reference!

## Contents

1	Introduction .....	3
1.1	Manufacturer .....	3
1.2	Terms and Conditions .....	3
2	Presentation of information .....	4
2.1	Symbols and terminology.....	4
2.2	Instructions for use and enumerations.....	5
3	Declaration of Conformity .....	6
4	Safety .....	8
4.1	General safety notes .....	8
4.2	Approved use .....	9
4.3	Non approved use .....	9
4.4	Notes and information in accordance with EN 795:2012 .....	10
4.5	Requirements in accordance with DIN EN 365:2004 .....	10
4.6	Obligations of the operator.....	11
4.7	Using several trolleys to secure persons.....	11
4.8	Securing on the anchor device.....	12
5	Technical data .....	13
6	General Data .....	14
6.1	The following data is engraved on the individual components of the Aluminium Gantry Crane:	14
6.2	Additional marking on the gantry crane with regard to attachment point .....	15
7	Delivery and transport .....	17
7.1	Scope of delivery .....	17
7.2	Transportation .....	17
7.3	Storage .....	17
8	Overview of individual components of the Aluminium Gantry Crane .....	18
9	Assembly .....	19
9.1	Additional assembly instruction for separable/pluggable beam versions (if ordered) .....	25
9.2	Additional Information of wheel kit for Aluminium Gantry Crane (if ordered).....	27
10	Putting into operation .....	30
10.1	Compulsory prior inspection and testing.....	30
10.2	Visual inspection, function test.....	30
11	Operation .....	31



---

12	Maintenance.....	32
12.1	Maintenance plan .....	32
12.2	Visual inspection, function testing and stress testing.....	32
12.3	Inspection report / repeat inspection.....	33
12.4	Checklist .....	36
13	Disassembly and Disposal.....	37
13.1	Disassembly.....	37
13.2	Disposal .....	37
13.3	Disposal of packaging material .....	37
14	Service .....	38
14.1	Contact .....	38
14.2	Spare parts ordering or reordering process.....	38

## 1 Introduction

- ▲ The Aluminium Gantry Crane is used for lifting, lowering and moving loads with a trolley. The Aluminium Gantry Crane is only permitted to be used on flat and solid surfaces. The Aluminium Gantry Crane can also be used as an anchor point in accordance with EN 795
- ▲ This user information constitutes an integral part of the product and an element of the overriding risk assessment and handling instructions to be taken into account whenever lifting or handling loads.
- ▲ The user information must be available to all users.
- ▲ Please read this user information thoroughly before using the Aluminium Gantry Crane.
- ▲ This user information explains how to safely assemble, operate, maintain, repair, disassemble and dispose of the Aluminium Gantry Crane.
- ▲ In addition to this user information, you must also observe and comply with all applicable occupational health and safety regulations of the country and the environment in which the Aluminium Gantry Crane is used as well as all other general regulations and rules regarding safe and appropriate use.
- ▲ Images and illustrations in this user information may differ from the actual product which will be supplied.
- ▲ Unauthorized modifications of the Aluminium Gantry Crane or self-made auxiliary equipment are prohibited.

### 1.1 Manufacturer



### 1.2 Terms and Conditions

- ▲ In the event of direct sales transactions, the General Terms and Conditions can be obtained from the manufacturer or from their website.
- ▲ If you have purchased your device from an intermediary, please ask your distributor/salesperson

## 2 Presentation of information

This user information uses symbols, terminology, instructions for use and enumerations as described in Chapters 2.1 to 2.2 below.

### 2.1 Symbols and terminology

#### Safety notes

Safety notes are categorised and presented as follows:

 <b>HAZARD</b>
A safety note designated as a “HAZARD” indicates a risk which will directly and with certainty lead to death or severe, permanent personal injury.

 <b>WARNING</b>
A safety note designated as a “WARNING” indicates a risk which may lead to severe personal injury or death.

 <b>CAUTION</b>
A safety note designated as a “CAUTION” indicates a risk which may lead to minor to moderate personal injury:

<b>NOTE</b>
A safety note designated as a “NOTE” indicates a risk which may lead to material damage.

#### Useful information and tips

	<b>INFO</b> This symbol indicates useful information and tips.
---	---

#### Disposal

	<b>INFORMATION FOR DISPOSAL</b> of packaging materials, lifting devices, etc.
---	--

## 2.2 Instructions for use and enumerations

All instructions for use are presented in chronological order and numbered, e.g.:

1. Step 1
2. Step 2

Outcomes of actions are indicated by an arrow:

- Outcome or device response

Instructions for use which do not have to be carried out in a particular sequence are indicated as follows:

1. Step 1
2. Step 2

Outcomes of actions are indicated by an arrow:

- Outcome or device response

Enumerations are indicated by indents:

- Enumeration

### 3 Declaration of Conformity

#### EC Declaration of Conformity

##### Pursuant to the EC Machinery Directive 2006/42/EC, Appendix II A

We hereby declare that the below mentioned machine complies with the general health and safety requirements of EC Directive 2006/42/EC and where applicable, 2014/34/EU; 2014/35/EU and 2014/30/EU in terms of its design and construction and in the version marketed by us. This declaration shall become invalid in the event of modifications to the machine without our prior approval.

#### Manufacturer:

SCHILLING Kran- und Hebeteknik GmbH  
Ernst-Zimmermann-Str. 9-11  
88045 Friedrichshafen  
Telefon: +49 (0) 7541 60404-0



#### Description and identification of the machine:

Designation: Aluminium gantry crane  
Item number: **sample documentation**  
Serial number:  
Load capacity:  
Year of construction:

#### Applied harmonised standards, in particular:

- DIN EN 12100:2011-03 - Safety of machinery
- DIN EN 13001-1:2015 – Cranes – General design – Part 1: General principles and requirements
- DIN EN 13001-2:2021 – Cranes – General design – T2 Load actions
- EN 13155:2003+A2:2009 – Cranes – Safety - Non-fixed load lifting attachments
- EN 16851:2017+A1:2020 - Cranes - Light crane systems
- EN 60204-1:2019-06 – Safety of machines
- DIN EN 60204-1 (VDE 0113-1):2019-06 – Electrical equipment of machines
- DIN EN ISO 80079-36:2016-12 – Nonelectrical equipment for use in potentially explosive atmospheres

#### Manufacturer:

SCHILLING Kran- und Hebeteknik GmbH, Ernst-Zimmermann-Straße 9-11, 88045 Friedrichshafen, Deutschland

#### Signaturet:

Martin Schilling – Managing Director

#### Date:

**Authorized person for documentation:** Danny Büdinger – Techniker (Maschinentechnik)

## UK Declaration of Conformity

### Supply of Machinery (Safety) Regulations 2008: Great Britain

We hereby declare that the below mentioned machine complies with the general health and safety requirements of Supply of Machinery (Safety) Regulations 2008: Great Britain in terms of its design and construction and in the version marketed by us. This declaration shall become invalid in the event of modifications to the machine without our prior approval

#### Manufacturer:

SCHILLING Kran- und Hebeteknik GmbH  
Ernst-Zimmermann-Str. 9-11  
88045 Friedrichshafen  
Telefon: +49 (0) 7541 60404-0



#### Description and identification of the machine:

Designation: Aluminium gantry crane  
Item number: **sample documentation**  
Serial number:  
Load capacity:  
Year of construction:

#### Applied harmonised standards, in particular:

- BS EN 13001-1:2015 – cranes - general design - part 1: general principles and requirements
- BS EN 13001-2:2014 – crane safety - general design - part 2: load actions
- BS EN 15011:2011 – cranes - bridge and gantry cranes
- BS EN 1999-1-1:2007+A2:2013 – design of aluminium structures – general structural rules

#### Manufacturer:

SCHILLING Kran- und Hebeteknik GmbH, Ernst-Zimmermann-Straße 9-11, 88045 Friedrichshafen, Deutschland

#### Signature:

Martin Schilling – Managing Director

#### Date:

**Authorized person for documentation:** Danny Büdinger – Techniker (Maschinentechnik)

## 4 Safety

Please read the safety instructions below thoroughly before putting the product into operation.

Chapters 4.1 to 4.3 set out general rules of conduct to be adhered to when handling the product. Instructions in the following chapters highlighted with a  symbol must be followed in order to avoid putting persons and materials at risk. Safety notes pertaining to individual instructions for use are listed before the relevant step and must be observed.

### 4.1 General safety notes

- Read this user information in full.
- Observe the safety notes.
- Ensure that this user information is available at the site of operation at all times.
- The product must be operated by suitably qualified personnel (see Tab. 1) only.
- In addition to this user information, you must also observe and comply with all applicable occupational health and safety regulations of the relevant country and environment in which the product is used, as well as other general regulations for safe and appropriate use.
- Any damage compromising safety must be repaired immediately.
- Perform all work prudently.
- Never open a lifting device when loaded.
- Never stand/walk below the suspended load..

#### Qualifications required for handling lifting devices

Field of activity	Qualification	Specialist knowledge
Delivery and transport	Dealer, freight carrier	Proof of load securing instruction
Storage	Warehouse staff	Storage and retrieval of technical equipment
Assembly, disassembly	Qualified personnel	Professional experience in the assembly and dismantling of technical equipment.
Operation, simple visual inspection	Qualified personnel	Trained crane operator, Advanced technical understanding, Knowledge of accident prevention regulations
Maintenance, repair, commissioning	Specialist	Authorized specialist personnel with extended technical understanding. Knowledge of occupational safety and Accident prevention regulation
Disposal	Qualified personnel	Knowledge of the regulations for proper disposal and reuse

Tab. 1: Overview

## 4.2 Approved use

- The lifting, lowering and moving loads with a trolley. The Aluminium Gantry Crane is only permitted to be used on flat and solid surfaces
- The stated load capacity must be observed
- Temperature ranges from -20° to +50°C
- Wind speeds of up to < 40 km/h
- When using the gantry crane, make sure that the beam length between the side frames is always at least 1.6 times the beam length outside the side frames.

## 4.3 Non approved use

- Exceeding the maximum load capacity
- Structural modifications of the product
- Standing/walking below the suspended load
- Pulling a load diagonally
- Forcefully freeing loads that are stuck
- Dragging loads along the ground
- Transporting persons and animals

No guarantee is provided for the completeness of Chapter 4.3.

Anything that is not explicitly permitted is classified as non approved use

## Use of the crane as an anchorage device in accordance with DIN EN 795:2012 Type B

The use of the gantry crane as an anchorage device for securing persons with personal protective equipment, in combination with the trolley, is type-tested.

Notified body: DEKRA Testing and Certification GmbH Bochum

If the crane is resold, the reseller is also responsible for passing on the documents in the national language.

### 4.4 Notes and information in accordance with EN 795:2012

- The anchor device (trolley) may only be used by a single user.
- A second person can secure themselves to the same anchorage for possible rescue.
- The fall arrest system used must be equipped with a means of limiting the maximum dynamic forces acting on the user during a fall arrest operation to a maximum of 6 kN.
- The surface must be designed for the load of the crane. When securing persons, this is at least 8 kN per foot.
- The stability of the crane must be ensured and checked before use.
- Depending on the load capacity and beam length of the crane, it may yield several millimeters in the event of a fall.
- When securing persons, no additional load may be attached to the anchor device (trolley).
- The anchor device may no longer be used as such if the inspection interval has been exceeded.
- Before each use, the device must be checked for any corrosion, deformation, cracks, etc.

### 4.5 Requirements in accordance with DIN EN 365:2004

- The anchor device (trolley) may only be used in combinations with a lanyard with energy absorber EN 355 and safety harness EN 361.
- The connecting element to the anchor point is part of the PPE and is subject to the EN 361 standard.
- The personal protective equipment may only be used by trained persons who have been instructed in its safe use and have the relevant knowledge.
- The user must not be impaired by illness, dizziness or alcohol.
- The operator must prepare a rescue plan that considers all possible emergencies that may occur during work.
- For safety reasons, the equipment must be withdrawn from use immediately if there is any doubt as to its safe use or if the equipment has been subjected to a fall and may not be used again until a competent person has given written approval.
- It is essential for safety that the position of the anchorage device or anchor point and the way in which the work is carried out minimize free fall. It is essential that the anchorage device or anchorage point is above the user, an inclined pull must be avoided, more than 10° is not permitted!
- Before each use, it is necessary to ensure that there is sufficient free space below the user so that in the event of a fall, there is no risk of being caught.

#### 4.6 Obligations of the operator

- The anchor point must be visibly in perfect condition.
- The load suspension pin must be visibly engaged.
- The trolley as an anchor point must be positioned above the person to be secured and secured with the locking device (red strap).
- Only one person may be secured to a trolley!
- Another person may attach themselves to the same point for rescue purposes.
- Depending on the load capacity of the crane, additional trolleys can be attached as anchor points.
- Never use an anchor point to lift a load and to secure persons at the same time.
- No modifications or additions may be made to the equipment without the prior written consent of the manufacturer.
- All repairs must only be carried out in accordance with the measures specified by the manufacturer.
- The intervals for regular inspections, considering legal regulations, type of equipment, frequency of use and environmental conditions, are a maximum of 12 months. If necessary, these intervals should be closer.
- The regular inspections can only be carried out by a competent person and in strict compliance with the manufacturer's instructions.
- The legibility of the product labeling must also be checked.

 <b>DANGER</b>
When securing persons to the trolley (attachment point), it must be locked (close brake with red strap).

#### 4.7 Using several trolleys to secure persons

- Depending on the load capacity of the gantry crane, up to 5 trolleys can be used so that up to 5 persons can be secured at the same time.
- If a trolley is used to carry a load, another trolley may be used in parallel to secure persons. This reduces the nominal load of the crane by 600 kg.
- If several trolleys are used to secure persons, the nominal load is reduced by a further 100 kg for each additional person to be secured.

Number of trolleys for securing persons based on the rated load capacity of the gantry crane:



## 4.8 Securing on the anchor device

The load bolts must be secured against unintentional loosening during use.

In the case of hexagonal load pins, this is done by fitting a lynch pin in the securing hole.

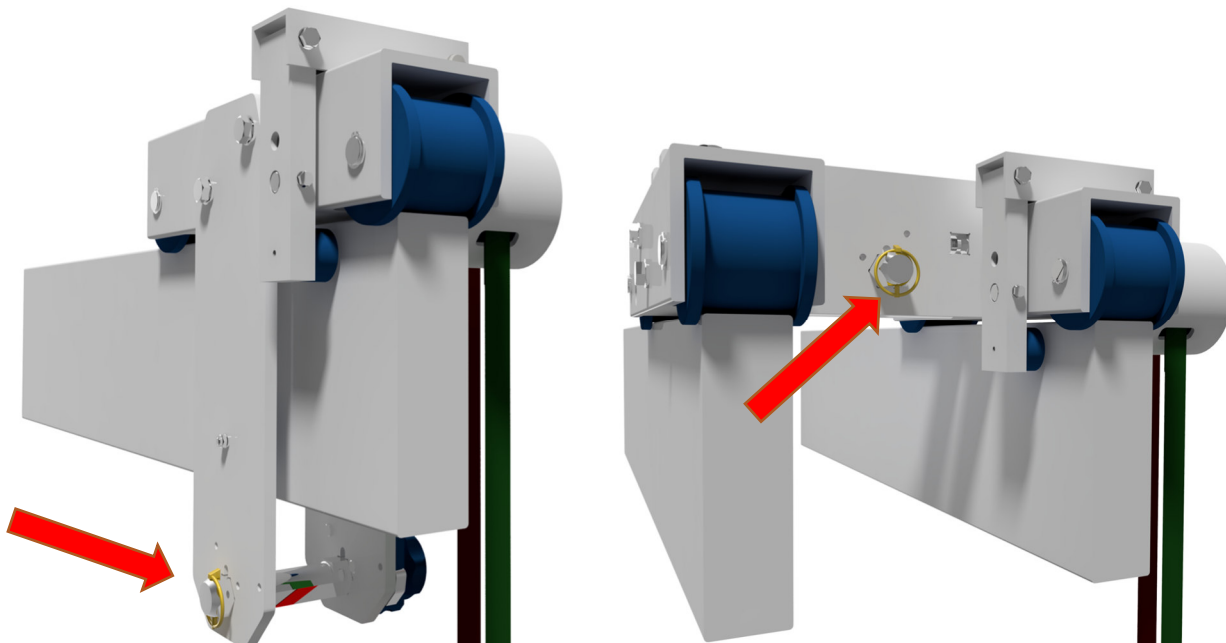

The bayonet of the round load pin must be locked, the handle must point downwards!

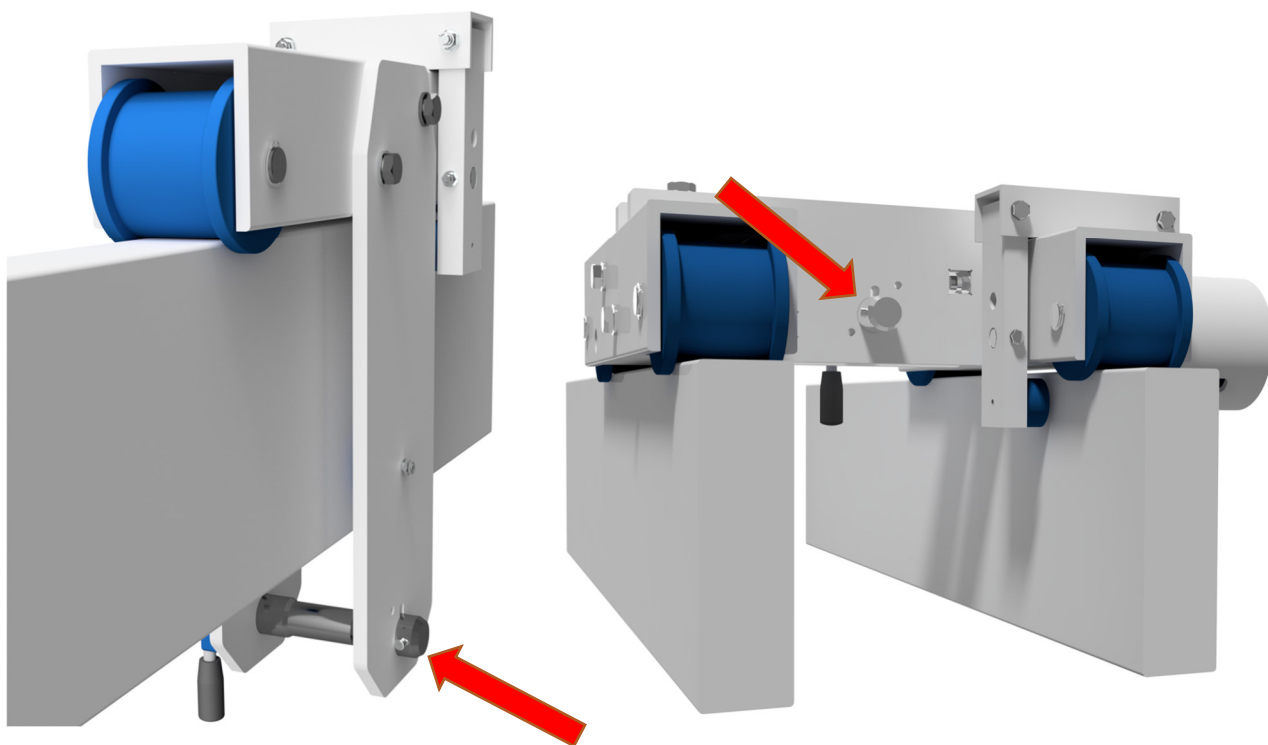

## 5 Technical data

Designation: Aluminium gantry crane

Item number: **sample documentation**

Serial number:

Carrier length:

Load capacity:

Year of construction:

### **Notes:**

Further information can be found under the article number in the enclosed documents or on our homepage.

## 6 General Data

6.1 The following data is engraved on the individual components of the Aluminium Gantry Crane:

Address label Manufacturer



Nominal load label



Example of a SCHILLING engraving:

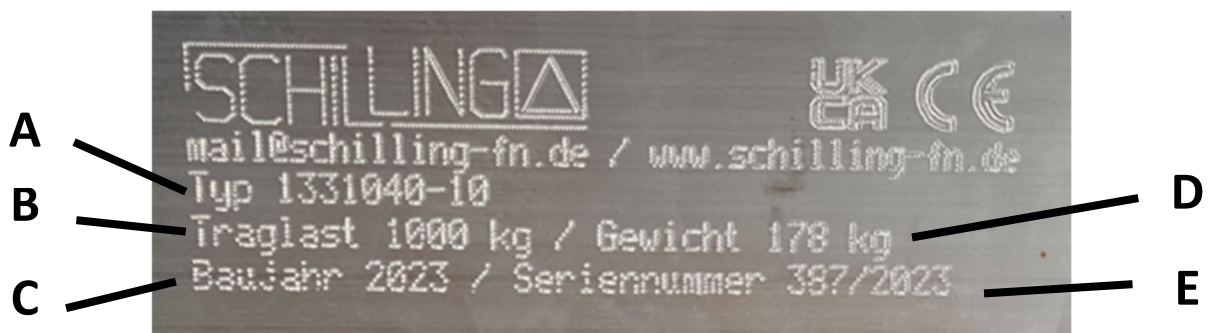

Explanation of the engraving details:

A: Type

B: Load capacity

C: Year of manufacture

D: Total weight

E: Serial number

## 6.2 Additional marking on the gantry crane with regard to attachment point

### Labeling on the gantry crane

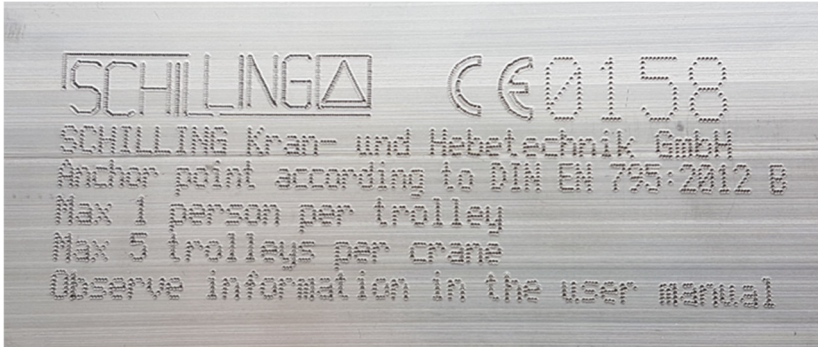

### Marking on the trolley



**Explanation of the engraving information:**

- A. Manufacturer (see also address label on product)
- B. Reference to anchorage device for securing persons in accordance with DIN EN795:2012 B
- C. Note: Only one person may be secured to each trolley. Any rescuer can also secure themselves.
- D. Depending on the crane load capacity, several trolleys can be used at the same time
  - a. Load capacity 500Kg 1 Trolleys
  - b. Load capacity 1.000kg 2 Trolleys
  - c. Load capacity 1.500kg 3 Trolleys
  - d. Load capacity 2.000kg 4 Trolleys
  - e. Load capacity 3.000kg 5 Trolleys
- E. CE marking with indication of the certification body (DEKRA Testing and Certification GmbH)

## 7 Delivery and transport

### 7.1 Scope of delivery

Immediately check the delivery for completeness against the enclosed delivery note.

You may also use the overview of the product and the parts list in order to verify the completeness of the delivery (see Chapter 8).

If parts are missing, please contact your supplier immediately.

If notified late, especially if the product has already been used, we cannot accept any claims for after supply.

### 7.2 Transportation

The product is checked and adequately packaged prior to delivery

NOTE
<p><b>Damage to the device</b></p> <p>Incorrect transportation may damage the product.</p> <ul style="list-style-type: none"><li>▪ Always transport the product as intended.</li><li>▪ Use a suitable means of transport.</li><li>▪ Make sure that the product is adequately secured during transportation.</li></ul>

### 7.3 Storage

NOTE
<p><b>Damage to the device</b></p> <p>Incorrect storage may damage the product.</p> <ul style="list-style-type: none"><li>▪ Always store the product as intended.</li><li>▪ Store the product in a clean and dry place.</li><li>▪ Protect the product from:<ul style="list-style-type: none"><li>- constant humidity or outdoor storage</li><li>- contamination</li><li>- damage</li><li>- corrosion</li></ul></li></ul>

## 8 Overview of individual components of the Aluminium Gantry Crane

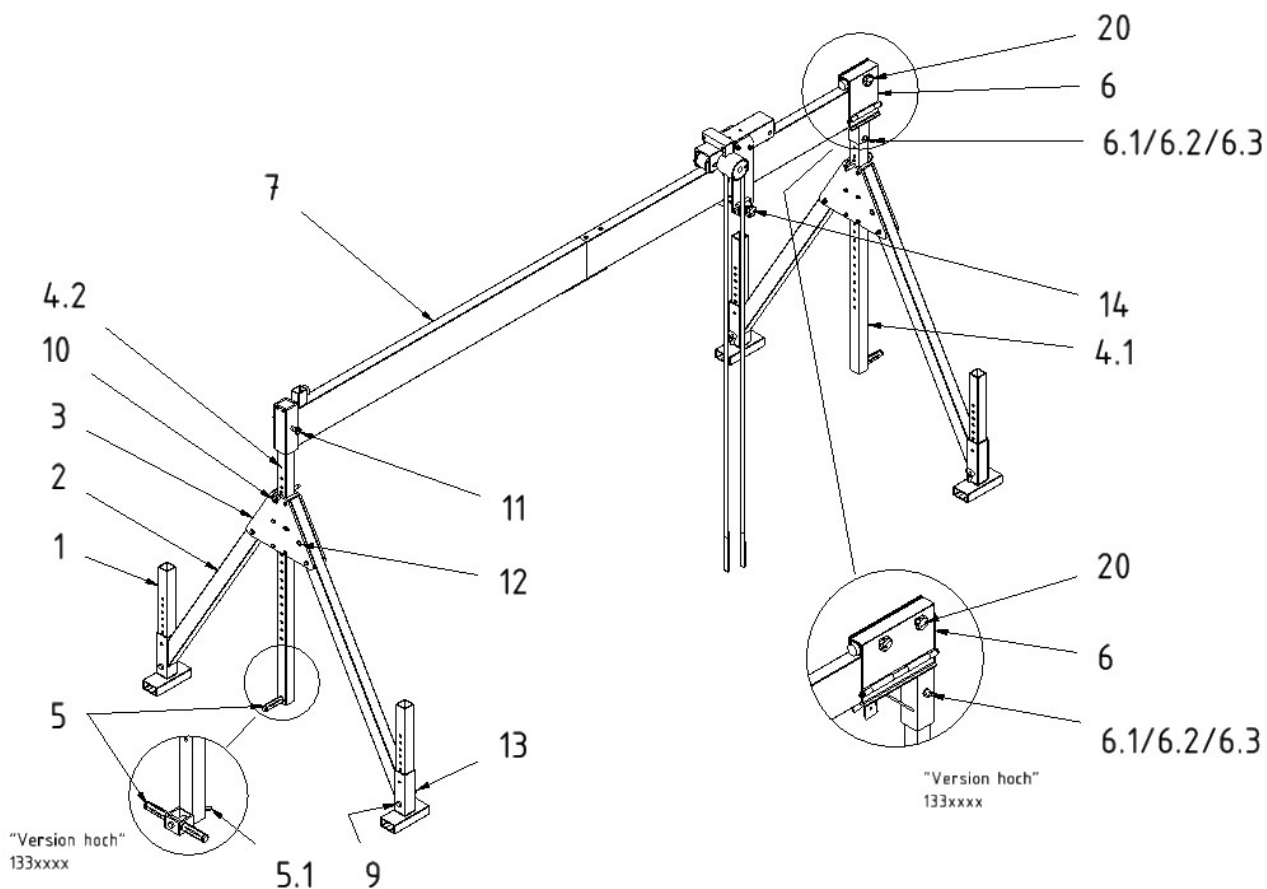

**Part list:**

Item	Name	Quantity	Item	Benennung	Stk
1	Adjusting feet	4	6.3	Nut	1
2	Stand brace	4	7	Aluminium beam	1
3	Plastic plates (trapezium)	2	8	Park brake trolley	1
4.1	Beam support "short"	1	9	Bolt, M16x100, for adjusting feet	4
4.2	Beam support "long"	1	10	Bolt (unlosable), D16, for beam support	2
5	Lifting handle	2	11	Bolt (unlosable), D16, for aluminium beam	1
5.1	Wing nut, M16	2	12	Push bolt	4
6	Horizontal adjuster	1	13	Wing nut, M16	4
6.1	Bolt, M16x130 "small/medium"	1	14	Suspension bolt (unlosable), for trolley	1
6.2	Bolt, M16x130 "high"	1	20	Star knob "small/medium"	1
6.2	Washer, M16	2	20	Star knob "high"	2

## 9 Assembly



### INFO

#### Recommended personnel, tools and aids for assembling the Aluminium Gantry Crane:

- At least 2 people, more if larger
- Socket or open-end wrench (if necessary)
- Step ladder or similar (if necessary), for larger cranes, lifting aids such as pulley blocks, forklifts, etc
- Individual parts can weigh over 100 kg

### ⚠ Caution

The Aluminium Gantry Crane has pinching points which may cause injuries.  
- Perform all assembly work prudently and cautiously.

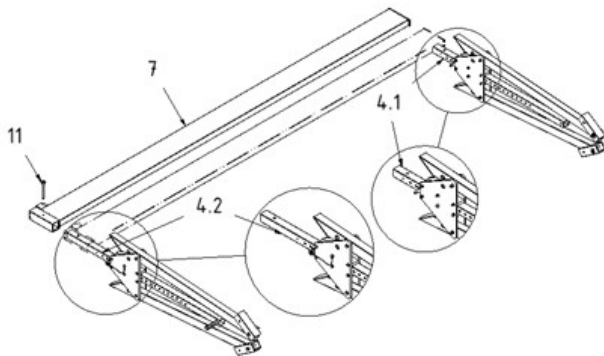

#### 1. Aluminium beam attachment:

##### 1.1.

Lay the 2 still folded lateral stands upright on a flat and solid surface.

(Bolt head on the trapezium outwards /nut inwards.)

##### 1.2.

Slide the beam housing (aluminium square profile), found welded on the end of the beam (7), onto the longer beam support (4.2).

##### 1.3.

Insert the bolt (11) into the hole in the beam housing of the beam (7) to secure the beam.

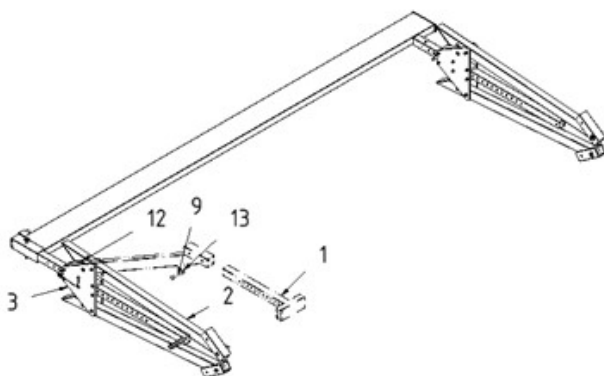

#### 2. First lateral stand unfolding (one side) and insertion of the first adjustment foot (alternative wheel kit):

##### 2.1.

Push in the pressure pin (12) on the upper stand brace (2) of the lateral stand.

##### 2.2.

Fold the stand brace (2) outwards (upwards) until the push bolt clicks and locks into the hole of the plastic plate (3).

##### 2.3.

Insert an adjustment foot (1) from below into the unfolded stand brace (2).

##### 2.4.

Secure the adjustment foot (1) using a bolt (9) with a clip pin (13).

**⚠ Caution**

The Aluminium Gantry Crane has pinching points which may cause injuries.  
- Perform all assembly work prudently and cautiously.

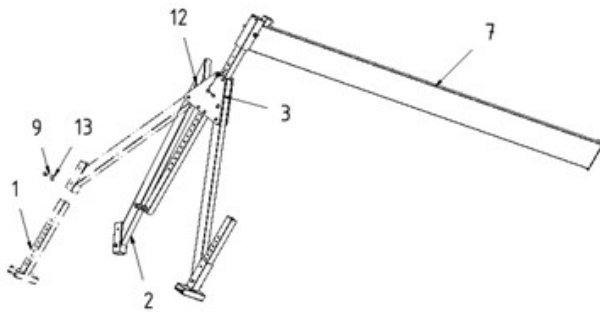

**3. Erecting, insertion of the adjustment foot (alternative wheel kit) and complete unfolding of the first lateral stand**

**3.1.**

Tilt sideways the entire lateral stand including beam (7) until the lateral stand is erect.

**3.2.**

Tilt slightly the lateral stand, so that the foot of the still folded stand brace (2) is free and can be easily unfolded.

**3.3.**

Push in the push bolt (12) on the upper stand brace (2) of the lateral stand.

**3.4.**

Fold the stand brace (2) outwards until the push bolt clicks and locks into the hole of the plastic plate (3).

**3.5.**

Insert the second adjustment foot (1) from below into the not yet unfolded stand brace (2).

**3.6.**

Secure the adjustment foot (1) using a bolt (9) with a nut (13).

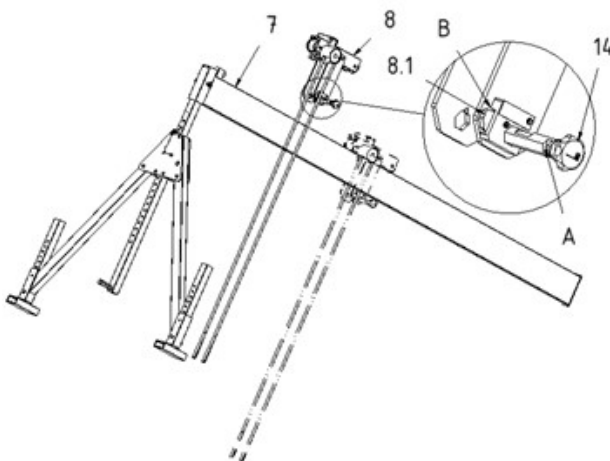

**4. Placing the trolley onto the beam:**

**4.1.**

Place the trolley (8) onto the beam (7) by pressing the locking mechanism (8.1) upwards and pulling out the suspension bolt (14).

**4.2.**

After positioning the trolley (8) on the beam, re-insert the suspension bolt (14) into the hexagonal hole.

**4.3.**

Ensure that after the re-insertion of the suspension bolt (14) that the locking mechanism (8.1) has snapped shut on the bolt groove (A).

**4.4.**

When the locking mechanism (8.1) has locked on the bolt groove (A) the safety hole (B) can be seen.

**4.5.**

Secure the trolley (8) against unwanted rolling by pulling firmly on the red band.

**⚠ Caution**

The Aluminium Gantry Crane has pinching points which may cause injuries.  
- Perform all assembly work prudently and cautiously.

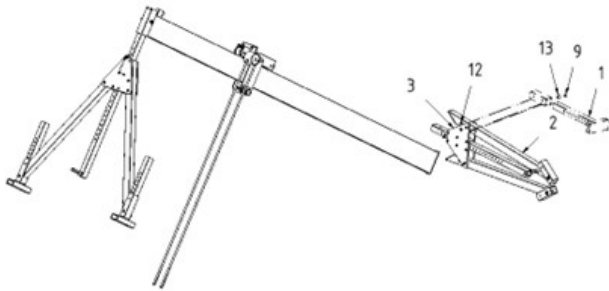

**5. Second lateral stand unfolding (one side) and insertion of the first adjustment foot (alternative wheel kit):**

**5.1.**

Push in the pressure pin (12) on the upper stand brace (2) of the lateral stand.

**5.2.**

Fold the stand brace (2) outwards (upwards) until the push bolt clicks and locks into the hole of the plastic plate (3).

**5.3.**

Insert an adjustment foot (1) from below into the unfolded stand brace (2)

**5.4.**

Secure the adjustment foot (1) using a bolt (9) with a clip pin (13).

**6. Completely unfolding the second lateral stand and insertion of the second adjustment foot (alternative wheel kit):**

**6.1.**

Rotate the lateral stand 180 degrees.

**6.2.**

Insert the second adjustment foot (1) from below into the not yet unfolded stand brace (2).

**6.3.**

Secure the adjustment foot (1) using a bolt (9) with a clip pin (13).

**6.4.**

Push in the push bolt (12) on the upper stand brace (2) of the second lateral stand.

**6.5.**

Fold the stand brace (2) outwards (upwards) until the push bolt (12) clicks and locks into the hole of the plastic plate (3).

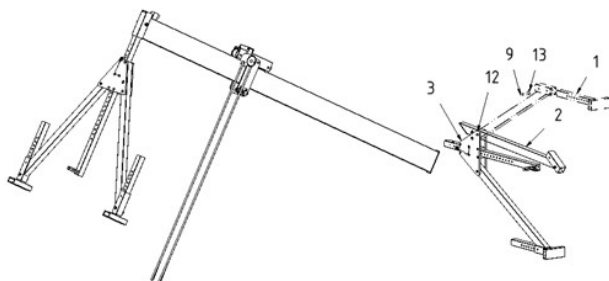

**⚠ Caution**

The Aluminium Gantry Crane has pinching points which may cause injuries.  
- Perform all assembly work prudently and cautiously.

**i** **INFO on assembly step 7**  
**Lateral stands with manual winch (if ordered):**  
- When the lateral stands are erected the winches must face outwards.

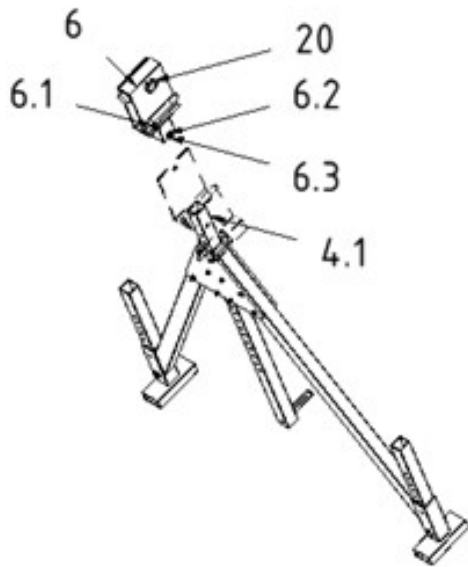

**7. Attaching the horizontal adjuster:**

**7.1.**

Erect the lateral stand and tilt it slightly.

**7.2.**

Slide the horizontal adjuster (6) onto the shorter beam support (4.1) of the lateral stand (bump stop facing inwards).

**7.3.**

Secure the horizontal adjuster (6) onto the beam support (4) using bolts (6.1), two washers (6.2) and nut (6.3).

**7.4.**

Open the horizontal adjuster (6) using the blue Star knob screw(20).

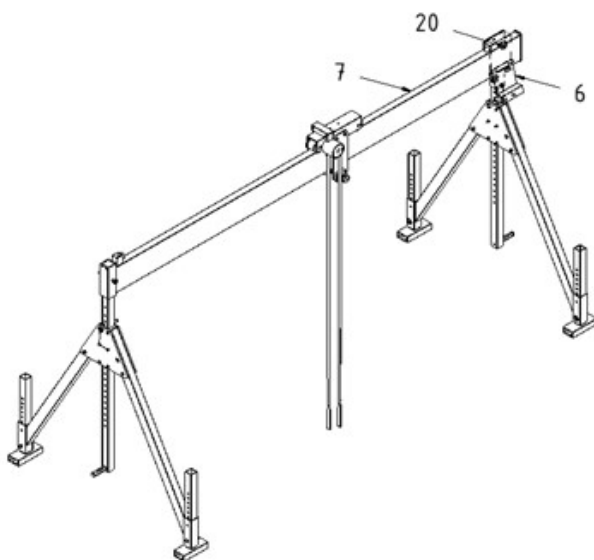

**8 Erection of the Aluminium Gantry Crane:**

**8.1.**

Erect the second lateral stand (one person).

**8.2.**

Lift the free end of the beam (7) (another person) and step, if needed, onto e.g. a step ladder.

**8.3.**

Lay the end of the beam (7) into the lower part of the already open horizontal adjuster (6).

**8.4.**

Close the lid of the horizontal adjuster (6). Securely clamp the beam (7) in the horizontal adjuster (6) by tightening the blue Star knob screw (20).

**⚠ Caution**

The Aluminium Gantry Crane has pinching points which may cause injuries.  
- Perform all assembly work prudently and cautiously.



**INFO on assembly step 9**

**Lateral stands with manual winch (if ordered):**

- Height adjustment of the beam supports (4.1/4.2) according to attached separate user manual.

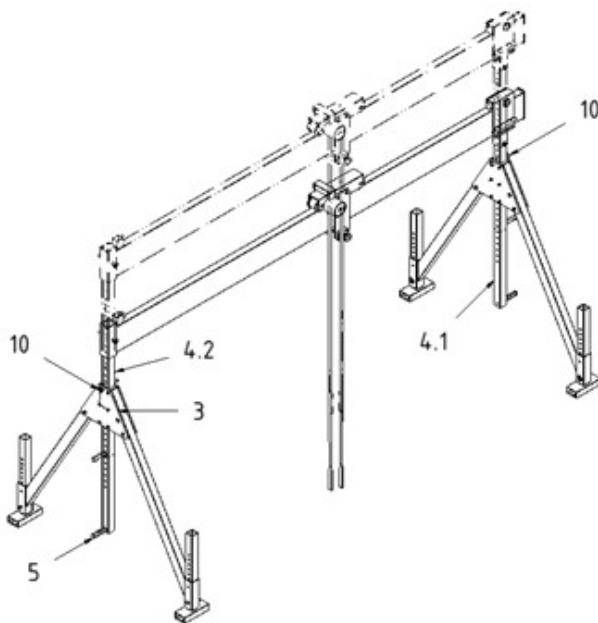

**9. Height adjustment of the Aluminium Gantry Crane:**

**9.1. (with lifting handles)**

Pull out the 2 bolts (10) from the beam supports (4.1/4.2). Simultaneously lift the 2 beam supports (4.1/4.2) with the lifting handles (5) and secure the required height with the bolts (10).

(Pay attention after inserting the bolts (10) that only the steel portion of the bolt lays in the groove of the plastic plates (3) and not on the plastic handle of the bolt.)

**9.2. (with hand winches)**

Height adjustment is according to the attached separate user manual.

**Caution:**

Before applying load to the crane the bolts (10) must always lay correctly in the plastic plates (3) and the rope of the winch must not be under tension.

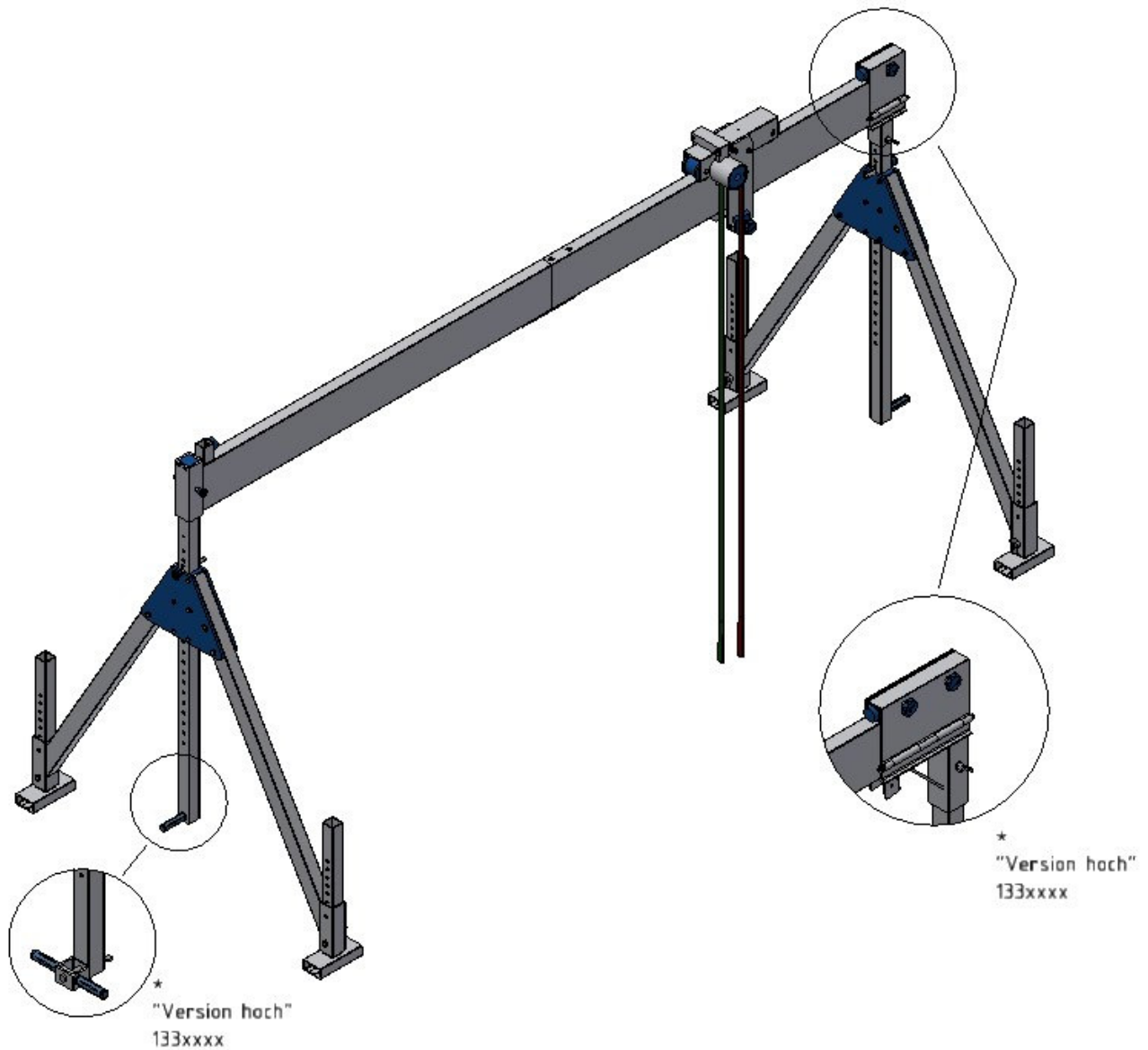

- **Now the Aluminium Gantry Crane is fully assembled**
- **Disassemble in reverse order, taking care to either remove the trolley from the aluminium beams, or at least to engage its brake during disassembly.**
- **Engage the brake to fix the trolley by pulling firmly on the red band.**

## 9.1 Additional assembly instruction for separable/pluggable beam versions (if ordered)



### INFO

**Recommended personnel, tools and aids for assembling the separable/pluggable aluminium beam:**

- M10 hexagonal socket wrench (allen key)

The following instructions describe the assembly of separable/pluggable aluminium beams.  
Disassemble in reverse order.

**Step 1:** Loosen the socket bolt (31) to loosen the bottom connecting element (32) so that you can more easily connect the aluminium beam (7B) with the aluminium beam (7A).

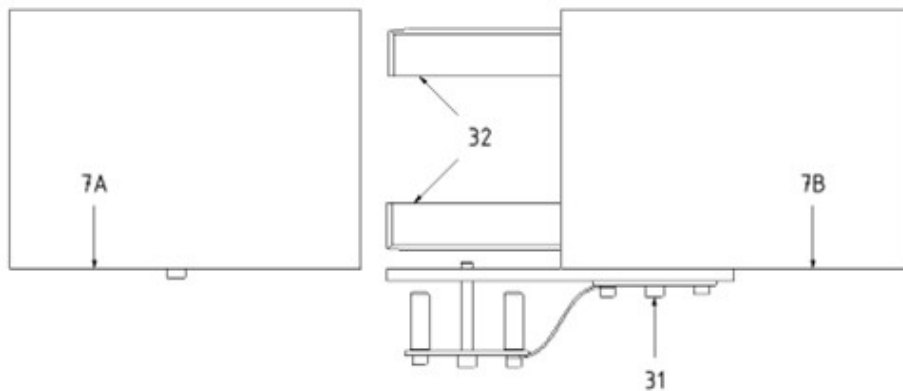

**Step 2:** Insert the connecting element (33), which is secured against loss by a securing rope (34), into the holes on aluminium beam (7A), and fix it with the socket bolt (35).

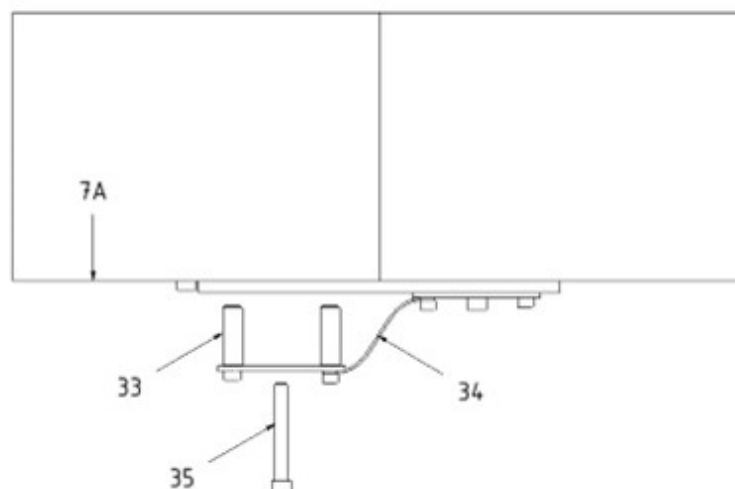

**Step 3:** Firmly tighten the socket bolts (31 + 35).

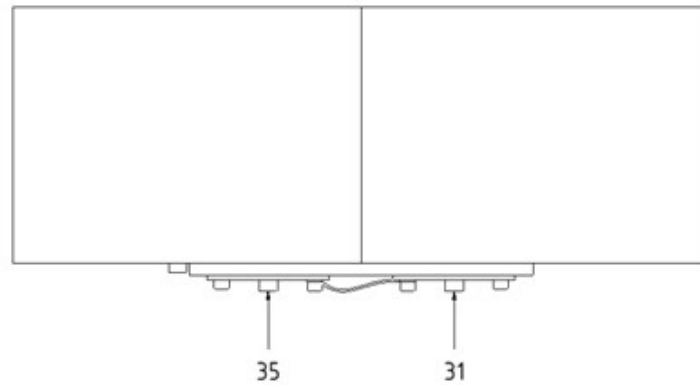

**Symbol image**

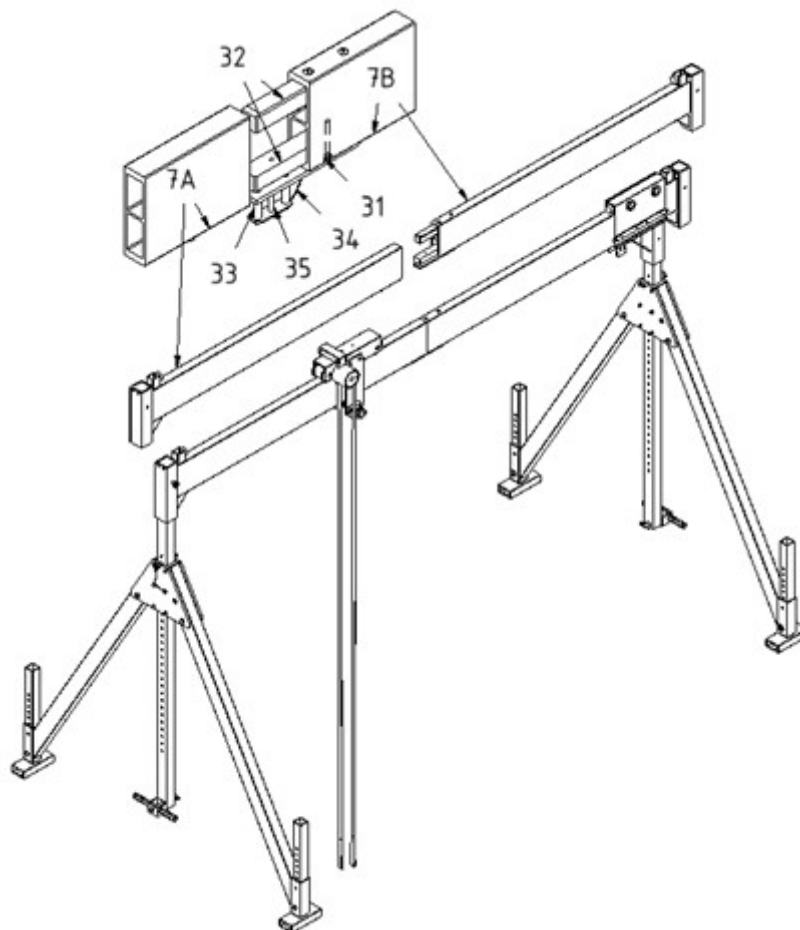

**Part list:**

Item	Name	Quantity	Item	Name	Quantity
31	Socket bolt, M10	1	34	Securing rope	1
32	Connecting element	2	35	Socket bolt, M10	1
33	Fixing element	1			

## 9.2 Additional Information of wheel kit for Aluminium Gantry Crane (if ordered)

### Depicted Aluminium Gantry Crane::

Double beam model with Wheel Kit for indoor use Item number 24001



**Figure:**

Wheel Kit for indoor use  
Item number 24001

Wheel Kit with heavy-duty  
polyurethane lining

**Figure:**

Wheel Kit for indoor- and outdoor use  
Item number 24002

Wheel Kit with Super-elastic-solid  
rubber tires

**Item No. 24001 – Indoor:  
Wheel Kit with heavy-duty polyurethane lining**



- For indoor moving and positioning of the Aluminium Gantry Crane without load
- 4 steel swivel casters
- with integrated caster and swivel head brake
- own weight 70 kg

**Attention:**

- When using this Wheel Kit together with our Aluminium Gantry Cranes
  - o the minimum suspension point at the bolt of the trolley is increased by 400 mm
  - o the maximum suspension point at the bolt of the trolley is increased by 200 mm
- the adjustment range of the Wheel Kit feet is 200 mm

**Item No. 24002 – Indoor and Outdoor:  
Wheel Kit with super-elastic-solid rubber tires**



- -For indoor and outdoor moving and positioning of the Aluminium Gantry Crane without load
- 4 steel swivel casters
- heavy duty tires with groove profile
- with integrated caster and swivel head brake
- own weight 80 kg

**Attention:**

- When using this Wheel Kit together with our Aluminium Gantry Cranes
  - o the minimum suspension point at the bolt of the trolley is increased by 440 mm
  - o the maximum suspension point at the bolt of the trolley is increased by 240 mm.
- the adjustment range of the Wheel Kit feet is 200 mm

**Description:**

- Facilitates moving of the fully assembled Aluminium Gantry Crane without load.
- The leg and fork construction permits the lateral stands to remain upright when assembling and disassembling.
- The unloaded Aluminium Gantry Crane can easily be moved to the working area.
- The Wheel Kit spares any assembly and disassembly work.
- The spring mounted guide rolls allow the lateral stands to rest directly on the feet when under load.

- The adjustment feet are individually height adjustable.
- 1 Wheel Kit = 4 „forks“.

## 10 Putting into operation

### 10.1 Compulsory prior inspection and testing

Inspection and testing of the Aluminium Gantry Crane is required prior to commissioning in order to ensure that the Aluminium Gantry Crane has been fully and correctly assembled.

In addition, this ensures that the Aluminium Gantry Crane is in perfect working order and ready for its intended use.

#### WARNING

Without prior inspection and testing, injuries may occur during commissioning.

Inspect and test the Aluminium Gantry Crane as follows:

- Visual inspection
- Function test

### 10.2 Visual inspection, function test

#### Visual inspection

The Aluminium Gantry Crane must be inspected every time before putting it back into operation.

#### CAUTION

The Aluminium Gantry Crane has pinching points which may cause injuries.

- Perform all inspections and testing of the Aluminium Gantry Crane prudently and cautiously..

1. The aluminium beams must be aligned horizontally.
2. The beam supports of the lateral stands must be aligned vertically.
3. Prior to loading the Aluminium Gantry Crane, all bolts must have been inserted and (if necessary) secured with clip pins.
4. The push bolts must have snapped into the plastic (trapezoidal) plates.
5. In particular, check load bearing parts for damage and broken weld seams.
6. Terminate operation in the event of faults. Faults must be eliminated by qualified personnel.

#### Function test

The Aluminium Gantry Crane must be tested every time before putting it back into operation.

#### WARNING

Loads may fall in the event of deformation and wear of individual components.

- Take the Aluminium Gantry Crane out of operation immediately.
- Have the device inspected and tested by a qualified expert.

1. Check that the brake on the trolley is functioning (green > open / red > closed).
2. Verify to what extent the individual components are still functional.
3. If in doubt, replace individual components.
4. Verify that all movable parts are able to move freely.
5. Replace parts which do not move freely.
6. Put the Aluminium Gantry Crane out of operation if no longer functional or damaged beyond repair.
7. Dispose of the individual material components (see Chapter 13).

## 11 Operation

The Aluminium Gantry Crane can be used as intended once it has been properly assembled and put into operation.

**⚠ CAUTION**

The Aluminium Gantry Crane has pinching points which may cause injuries.  
Operate the Aluminium Gantry Crane prudently and carefully.

**⚠ WARNING**

Various hazards may occur in connection with the Aluminium Gantry Crane.  
If the trolley brake is not engaged and the aluminium beam is at a slight incline, the trolley can move unexpectedly.  
If the Aluminium Gantry Crane is not operated as intended, injuries may occur when adjusting the beam supports.  
Select the distance between the two lateral stands so that the stability of the Aluminium Gantry Crane is ensured.  
If faults are identified at welded joints, a supporting part may break, causing the load to fall and potentially result in severe personal injury.

**⚠ DANGER**

Never work below a load on the Aluminium Gantry Crane.  
Never stand/walk below the suspended load  
Beim Sichern von Personen die einschlägigen Anweisungen beachten.  
Slack rope formation and any pendulum movements must be avoided.

The Aluminium Gantry Crane is used for lifting, lowering and moving loads with a trolley.

The trolley can be used as an anchor point for securing persons in accordance with EN795:2012.

The Aluminium Gantry Crane is only permitted to be used on flat and solid surfaces.

## 12 Maintenance

The product is essentially maintenance free.

### 12.1 Maintenance plan

Maintenance date	Action
Prior to putting into operation	- Visual inspection and function testing by qualified personnel
Prior to each subsequent operation, after initial putting into operation without any prior extraordinary incidents	- Visual inspection by qualified personnel
Annually	- Visual inspection, function testing and stress test performed by a qualified expert

Do not use concentrated acids or alkalis for cleaning, especially for non-metallic components. Do not use solvent-based cleaners here either.

### 12.2 Visual inspection, function testing and stress testing

#### Visual inspection

See chapter Commissioning → Visual inspection

#### Function testing

See chapter Commissioning → Function testing

#### Stress testing according to the relevant guidelines

The product must be subjected to stress tests at least once a year, and immediately in the event of modifications or repairs.

#### **WARNING**

Operators of the product are required to comply with statutory regulations.

- - Have the device professionally inspected by a qualified expert (see next Chapter)

1. Operators of the product must ensure that the product is inspected by a qualified expert at least once a year and that any faults identified during these inspections are eliminated immediately.
2. (Where applicable) The guidelines of the DGUV Vorschrift (regulations) 52 (BGV D6) – UVV Krane (cranes), must be observed.

### 12.3 Inspection report / repeat inspection

The date of the next outstanding inspection must be entered.

**The maximum interval is 1 year**

If the device is used for personal safety, we recommend every 6 months

Shorter intervals for intensive use in appropriate environments

<b>Hersteller:</b>	SCHILLING Kran- und Hebetchnik GmbH – <a href="http://www.schilling-fn.de">http://www.schilling-fn.de</a> Ernst-Zimmermann-Str. 9-11 88045 Friedrichshafen
<b>Product:</b>	Aluminum gantry crane
<b>Load capacity:</b>	
<b>Part number:</b>	sample documentation
<b>Serial number:</b>	
<b>Year of manufacture:</b>	

1.)	Inspection prior to delivery. Visual inspection and function testing of the product and its components have been performed. The product has been developed, constructed and built in accordance with the rules of engineering.
Date: Date of dispatch (see delivery note)	Owner's/Manufacturer's signature

2.)	Commissioning test / start of use The test has been carried out
Date:	Signature of the qualified expert

3.)	Due date of the next repeat inspection	Date:
Inspection has been performed		
Date:	Signature of the qualified expert	

4.)	Due date of the next repeat inspection	Date:
Repeat inspection Inspection has been performed		
Date:	Signature of the qualified expert	

5.)	Due date of the next repeat inspection	Date:
Repeat inspection Inspection has been performed		
Date:		Signature of the qualified expert

6.)	Due date of the next repeat inspection	Date:
Repeat inspection Inspection has been performed		
Date:		Signature of the qualified expert

7.)	Due date of the next repeat inspection	Date:
Repeat inspection Inspection has been performed		
Date:		Signature of the qualified expert

8.)	Due date of the next repeat inspection	Date:
Repeat inspection Inspection has been performed		
Date:		Signature of the qualified expert

9.)	Due date of the next repeat inspection	Date:
Repeat inspection Inspection has been performed		
Date:		Signature of the qualified expert

10.)	Due date of the next repeat inspection	Date:
Repeat inspection Inspection has been performed		
Date:		Signature of the qualified expert

11.) Due date of the next repeat inspection	Date:
Repeat inspection Inspection has been performed	
Date:	Signature of the qualified expert

12.) Due date of the next repeat inspection	Date:
Repeat inspection Inspection has been performed	
Date:	Signature of the qualified expert

13.) Due date of the next repeat inspection	Date:
Repeat inspection Inspection has been performed	
Date:	Signature of the qualified expert

14.) Due date of the next repeat inspection	Date:
Repeat inspection Inspection has been performed	
Date:	Signature of the qualified expert

15.) Due date of the next repeat inspection	Date:
Repeat inspection Inspection has been performed	
Date:	Signature of the qualified expert

16) Due date of the next repeat inspection	Date:
Repeat inspection Inspection has been performed	
Date:	Signature of the qualified expert

Continue the list yourself if required

### 12.4 Checklist

Test template for duplication. File the completed copy with the documentation

<b>Product:</b> Aluminium gantry crane			
<b>Load capacity:</b>			
<b>Part number:</b> sample documentation			
<b>Serial number:</b>			
<b>Year of manufacture:</b>			
<b>Manufacturer:</b> SCHILLING Kran- und Hebetchnik GmbH – <a href="http://www.schilling-fn.de">http://www.schilling-fn.de</a> Ernst-Zimmermann-Straße 9-11 – 88045 Friedrichshafen			
Test instructions, if components are available. No claim to completeness.			
ok	not ok	not relevant	<b>Test result OK, components in proper condition?</b> <b>List can / must be continued accordingly.</b>
			Good general condition
			Function and condition of chassis, wheels, bearings, brakes?
			Load-bearing profiles, beams, struts free of cracks, without any influencing damage?
			Screw and plug connections tight and in order? Holes not knocked out?
			Plastic elements no relevant cracks? No embrittlement?
			Trolleys without cracks, rollers and bearings in order, brakes working properly?
			Chains, ropes, straps without visible damage?
			Electrical components in order, VDE tests carried out if necessary?
			Documentation available, signs and labels present and legible?
			Load test carried out? Nominal load for 10 minutes, no permanent deformation?
If there are defects, these must be rectified by the manufacturer or a specialist company using original spare parts. The defects have been professionally rectified and the product is ready for use:			
Date and signature of the plant manager:			
The product is free of defects and can be used until the next test:			
Date and Signature of the qualified expert:			

## 13 Disassembly and Disposal

As manufacturers, we are required by law to inform you not to dispose of the product as unsorted waste. Dispose of it separately via collection and return points for industrial and commercial waste.

The product must therefore be disassembled into its individual components.

### 13.1 Disassembly

#### CAUTION

Disassembly of the product on unstable surfaces or by means of unsuitable tools may result in injuries.

1. The assembled product is disassembled in the reverse order to that described in Chapter 9.
2. The individual assemblies of the product must then be disassembled by means of a suitable tool.

### 13.2 Disposal



#### INFORMATION FOR DISPOSAL

If the product is no longer functional or cannot be repaired, it must be disposed of in accordance with the applicable regulations.

The product consists of several different material components which must be disposed of separately:

1. Dispose of aluminium components as scrap aluminium.
2. Dispose of metal components as scrap metal.
3. Dispose of plastic components as scrap plastic.
4. Dispose of electrical components as electrical scrap (when using an electrical chain hoist).

### 13.3 Disposal of packaging material



#### INFORMATION FOR DISPOSAL

Packaging material must be correctly disposed of or recycled.

## 14 Service

### 14.1 Contact

For service matters or all other enquiries, please contact your supplier.

### 14.2 Spare parts ordering or reordering process

**INFO**

Please use the overview and table in Chapter 8 for better identification of the required component and submit this to your supplier.

1. Determine the serial number of your product. The serial number can be found in this user information in Chapter 3. The serial number is also engraved on the product.
2. Determine the year of manufacture of the product. The year of manufacture can be found in this user information in Chapter 3. The year of manufacture is also engraved on the product.
3. Use the overview in Chapter 8 and highlight the component or assembly in question.
4. Then contact your supplier directly, submitting the collected data and any other details.

